

1.4 Threaded stud (type MPF)

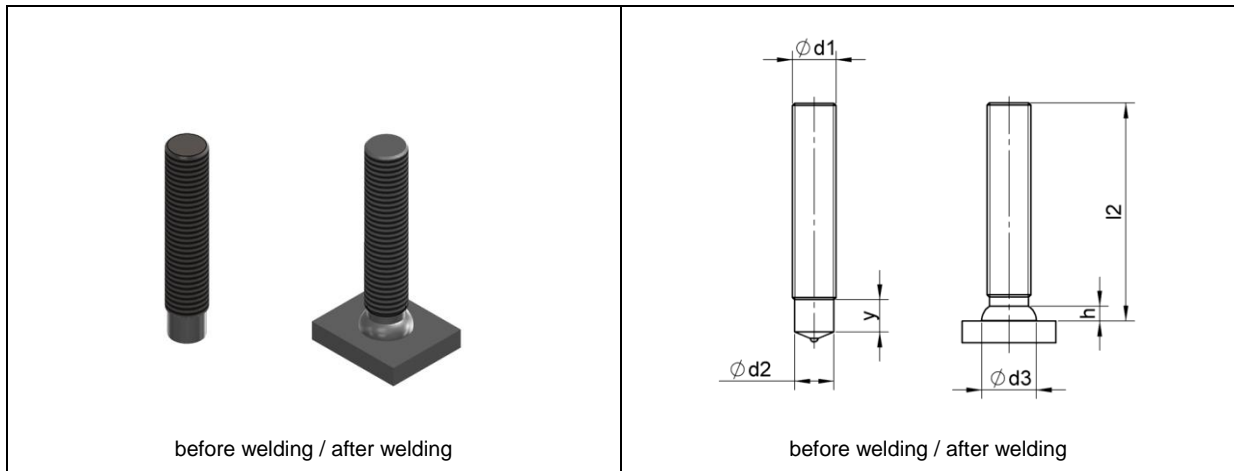

The threaded stud type MPF is threaded to approximately the top of the welding tip. The diameter of the unthreaded stud section on the welding tip corresponds to the pitch diameter of the thread. Thus the diameter of the weld-fillet is approximately 3-4 mm larger than the external diameter of the thread.

Dimensions					
d_1	l_2	y -0/+0,5	d_2	d_3^*	h^*
M6	15-100	3	5,3	8,5	4
M8	15-100	6	7,1	10	3
M10	15-100	7	8,95	12,5	3,4
M12	20-100	8	10,8	14,5	4,2
M16	30-100	11	14,6	17,8	5,8
M20	35-100	13	18,3	22,5	6,6

* d_3 and h are approximate values.